



installation Manual

HomEvap All Seasons

This product may be used by children aged from 12 years and above and persons with reduced mental capabilities, physical limitations or lack of experience and knowledge if they have been

Oorspronkelijke gebruiksaanwijzing Nederland, Original manual Netherlands
HomEvap Kerkenbos 1334 6546 BG Nijmegen, Netherlands

All rights reserved.

The information applies for the standard product design. HomEvap BV cannot therefore be held liable for any damage arising from product specifications deviating from the standard design. The available information has been compiled with every possible care, but HomEvap BV cannot be held liable for any errors in the information or for the consequences of this. HomEvap BV cannot be held liable for damage arising from work carried out by third parties.

Subject to modifications.

Section 1 – Safety regulations

HomEvap B.V. accepts no liability for damage or injury caused by not (strictly) complying with the safety regulations and instructions, or by carelessness during the installation and/or use of the product.

This product is not intended for use by persons (including children) with reduced physical, sensory or mental capacity, or lack of experience and knowledge, unless they are supervised or instructed in the use of the product by a person who is responsible for their safety.

1.1 Safety measures taken

- The All Seasons is constructed in such way that it is not possible to come into contact with moving or live parts during normal use and without specific actions.
- The All Seasons meets the statutory requirements that are laid down for electrical

ENGLISH

- equipment for light household use, protection class II.

The following safety measures must be taken into account:

- Before starting work always turn off the power to the product by removing the power cable from the socket and turning off the water supply.
- Use appropriate/suitable tools.
- Fitting the product above open electrical installations such as power distribution cabinets, sockets, etc. should be avoided at all times. If this is not possible provisions should be taken to prevent damage and/or hazardous situations due to water leaks.
- The All Seasons shall be installed in accordance with the national wiring regulations.
- If the main supply cord is damaged, it must be replaced by authorised persons.
- Only use the product for an application for which the product is designed as described in Sections 11 – 'Warranty provisions' and 12 – 'Liability' and follow the fitting instructions as described in these installation instructions. Any adjustment to the product connections are for the risk and account of third parties.

1.2 Hazard symbols

The All Seasons bears the following recognisable and clear hazard symbols to warn you:



This symbol warns you of contact and risk of electrical voltage or water contact.



HIGH VOLTAGE

The components under the bottom cover are live, if power supply is connected.

Careful operation is required.

Remove the plug from the socket before you dismantle/remove the cover!



WARNING

This symbol warns you of an electrical hazard. Careful operation is required.

Section 2 – Delivery

Check the packaging on receipt and before opening for visible damage. Damage must be reported to HomEvap in writing within 48 hours after delivery.

2.1 Scope of supply

The All Seasons consists of:

2 EPP housings fitted with 2 round connections of R200 mm.

The following components have been fitted in/on the HomEvap housing humidifier:

- One fibreglass (1) absorbent matrix cassette with LegioSafe water filter
- One (1) PTC electric heating element
- One (1) cord with connection adapter for SHC80 sensor (L=1m)
- One (1) water supply hose black(L=1m; Ø=4mm; adapter 3/4" outside)
- One (1) cord with coupling for cord with mains plug (L=1m)
- One (1) cord fitted with a pt1000 temperature sensor T3 (L=2m)
- One (1) cord for connecting the humidifier with the basic cooler



Basic Cooler:

- One fibreglass (1) absorbent matrix cassette
- One (1) cord for connecting the cooler with the humidifier
- One (1) water supply hose black(L=1m; Ø=4mm)

Supplied separately are:

- One (1) combined humidity-temperature sensor (SHC80)
- One (1) cord with coupling for cord with mains plug (230VAC; L=1m)



- All Seasons controller



Section 3 – Operation

The purpose of the unit is to humidify dry air passing through a wetted media in an energy-efficient, silent and safe way. The adiabatic humidification/cooling process is carried out in the humidifier and cooler itself and increases the humidity in the air supply to the room/ house or cools the temperature.

3.1 Principle of operation

Humidifier

The humidifier is to be located in the air supply duct after the heat recovery ventilation (HRV) unit. If the humidity content of the outside air becomes too low the humidifier starts. The process is as follows: HRV unit heats up the incoming air using a heat exchanger, as a result the relative humidity level drops, this dry warm air passes through the HomEvap which raises the humidity to the setpoint set, using the principle of evaporation of water which is safe and droplet free.

The air does however cool down according to the enthalpy line of the Mollier diagram. The built-in PTC air heater only heats the air if the temperature after the humidifier is lower than 17°C. The maximum capacity is 3kg/h. The used water quantity is accurately controlled by the software program for economic water consumption.

In this case, no guarantee can be provided regarding a minimum room humidity percentage. We supply the blown air with a minimum of 5.5 grams per kilogram of air when the humidifier is operational. On average, it will be around 7 grams per kilogram of air.

Indirect cooling:

With indirect cooling, the cooled air is stored in the WTW, so that the so-called heat exchanger becomes a cold exchanger. The fresh, warm outside air passes over the cold exchanger and is cooled in the house. This function is activated when the outdoor temperature rises above 18 degrees and there is demand.

Direct cooling:

With direct cooling, the HomEvap Humidifier is placed on the air supply duct after the HRV and only comes into operation if the outside temperature is experienced too hot and the setpoint is lower than the measured temperature in the home. Over-humidification is avoided by the combined moisture / temperature sensor in the duct to the house. This function is activated when the outdoor temperature rises above 22 degrees and there is demand.

When will which unit work?

The All Seasons is controlled by the outside temperature sensor. This determines when which unit is allowed. If the temperature is between 12 and 18 degrees, the unit will be off and the display shows OFF. Below the setpoints when which function may work:

- Humidifier: below 12 degrees outside temperature (TS04).
- Indirect cooler: above 18 degrees outside temperature (TS05).
- Direct cooler: above 22 degrees outside temperature (TS06).

These setpoints can be adjusted in the technical menu. NOTE: TS04 cannot exceed TS05, TS05 cannot exceed TS06.

ATTENTION: the effect on the room temperature is limited by the limited air volume.

3.2 Safety

The water is legionella-safe because of the built-in, patented, legionella-free LegioSafe water filter and distributor. The supply water first passes through the LegioSafe before it moistens the matrix. As a result there is no risk for the inhabitants of houses or building. Only fresh water is used. There is no recycling of water. The matrix is completely dry if there is no demand for cooling/humidification.

The SHC80 duct sensor supplied also measures the relative humidity and temperature in the duct after the humidifier. This position guarantees the best efficiency and safe operation, no condensate in ducts under the normal conditions of use of our design.

The built-in PTC air heater has several safety devices:

1. A mechanical safety device that ensures that the air heater demands no more power after exceeding a maximum temperature of 85°C.
2. An extra temperature sensor in the humidifier that switches the air heater off at too high a temperature.

Section 4 – Use

The All Seasons can be used on any HRV type where moisture is not exchanged between supply and return air.

4.1 Description of the components

The main components of the humidifier are:

The housing

The housing of the humidifier and cooler is made of EPP (expanded polypropylene). The advantages of this material are its low weight, good water tightness, good air tightness and recyclability. The housing consists of an upper and a lower part that are fixed to one another by two Mounting rings. At the bottom is the compartment there is a water valve, controller board and transformer located. These are protected by an EPP cover bearing safety symbols. On left and right side the duct connection is located, diameter R200mm internal and 250mm outside

Internal construction humidifier

The internal construction has been developed to provide an optimum air flow that is safely humidified. It consists of a cassette in which the patented legionella-safe filter, LegioSafe and the matrix are fixed. The supply water passes through the filter after which the filtered water humidifies the matrix. The air supplied passes through the matrix and is humidified by contact with the wet surface. Surplus water is drained. The PTC air heater heats the air supplied if this falls below the setpoint.

Internal construction cooler

The basic cooler consists of a cassette and a water distributor and a 24vdc water valve and a 15mm water outlet.

Humidity and temperature sensor (SHC80)

The SHC80 duct sensor also supplied measures the relative humidity and temperature in the duct after the humidifier. This position guarantees the maximum operation and condensate-free ducts under the normal conditions of use of our design.

T3 sensor

Outside temperature sensor. Is installed in the incoming outside air duct.

The control

The All Seasons is controlled by a (wireless) control panel.

This control panel fitted with batteries (4xAAA) is linked uniquely to the humidifier. See separate Controller manual.

Operation

As soon as the humidity sensor in the control panel measures a lower humidity than the setpoint it activates the humidifier. As soon as the temperature sensor in the control panel measures a higher temperature than the setpoint it activates the cooler. The software has been developed to achieve an optimum output and minimum water consumption, at the lowest energy costs.

Safety

The control is fitted with an Legionella flushing program, in addition the control has a number of other built-in safety devices and indication functions.

The signalling lights of the control PCB are at the bottom of the humidifier.

The necessary reports are also transferred to the display.

Section 5 – Technical specifications

5.1 Specifications

Description	
Dimensions LxBxH	258 x 344 x 340 mm
Humidification capacity	0-4 litre
Electricity consumption	20 VA/900VA peak
Maximum water consumption	5 litre per hour
Water supply connection	¾ internal thread with connection to 4mm
Water drainage connection	16 mm hose grommet 50cm
Maximum air volume	600 m3/u
Duct connection	Standard r200

5.2 Illustrations Cooler

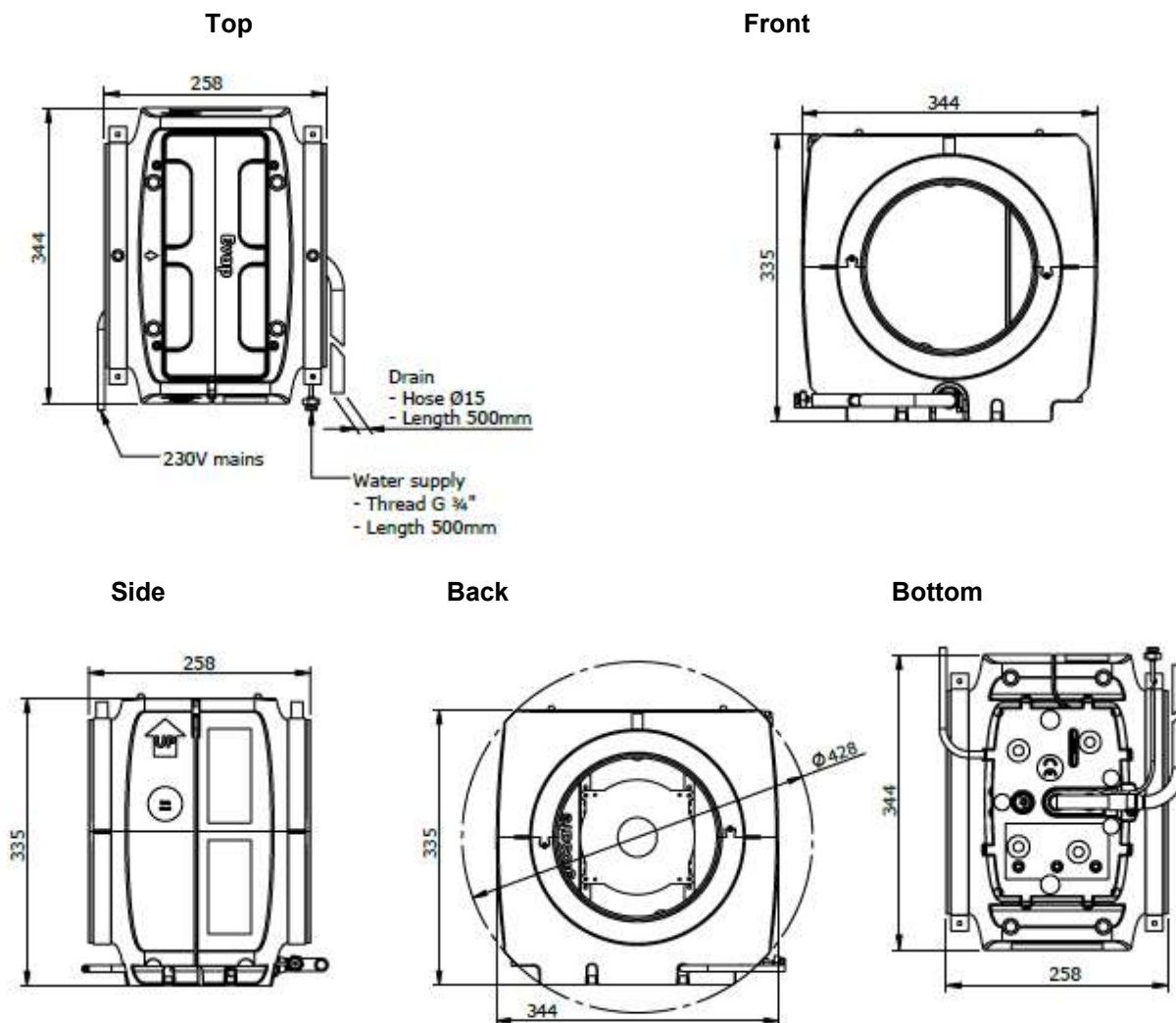

Exploded view Basic Cooler and Humidifier

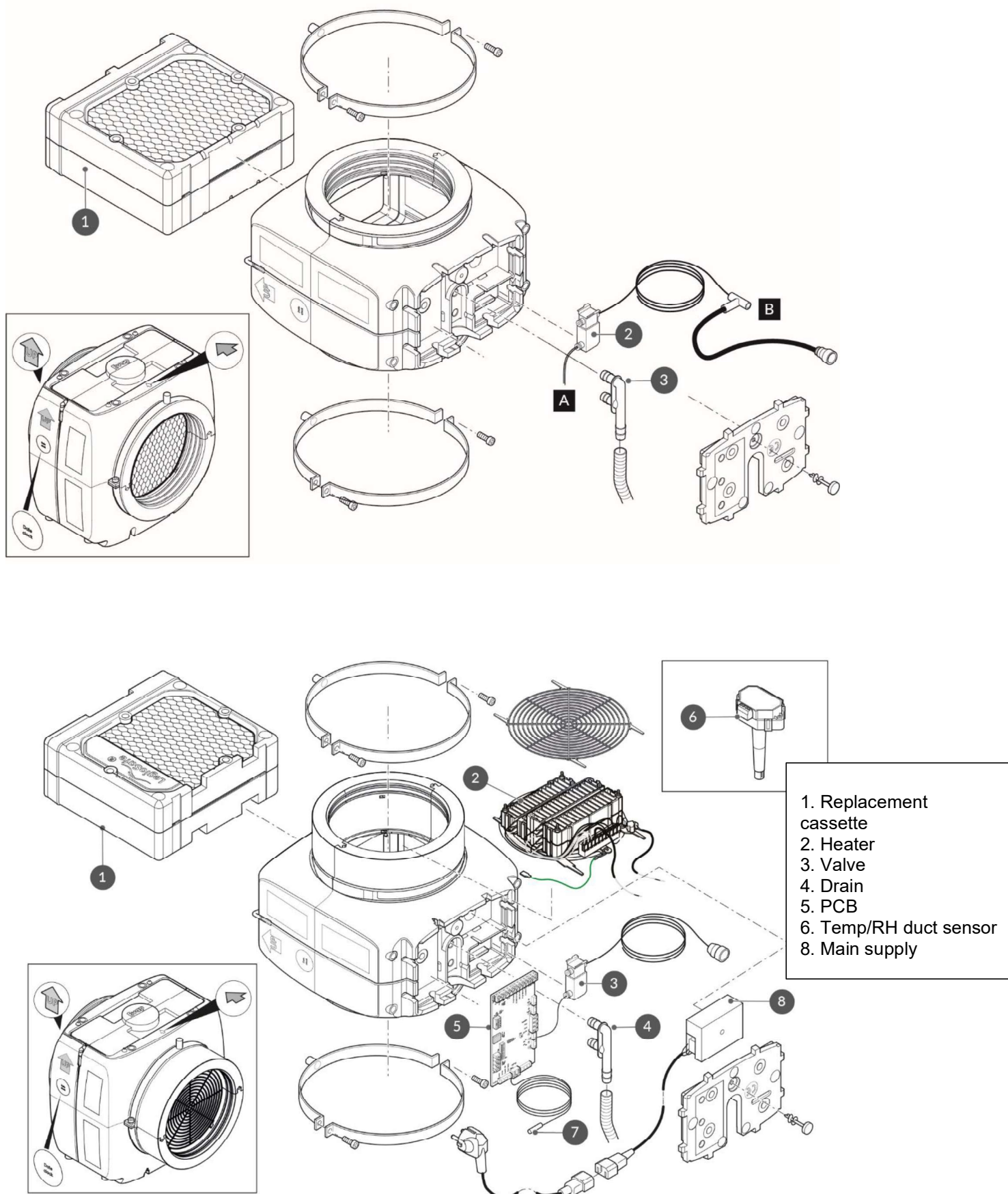

- 1. Replacement cassette
- 2. Heater
- 3. Valve
- 4. Drain
- 5. PCB
- 6. Temp/RH duct sensor
- 8. Main supply

Section 6 – Installation

6.1 Order of operation

1. Choose the location of the humidifier in the air supply duct as close as possible to the HRV unit. The minimum distance after a bend is 150mm.
2. It is important that during installation sufficient space is available so that the unit can be rotated at time of doing service= replacing matrix cassette. At least 200mm from the ceiling.

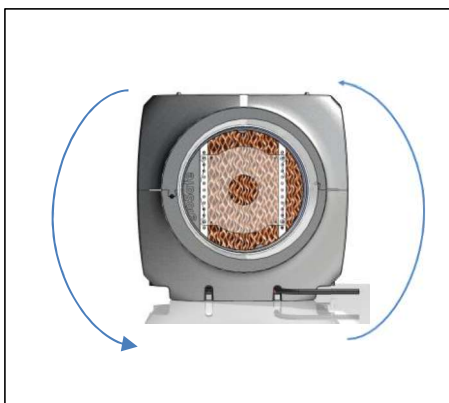

Note! Unit must be mounted level in all directions

3. Keep at least 100 millimetres clear space at the bottom.
4. Install the humidifier horizontally between the ducts or air hoses. The unit must hang level to guarantee good water drainage.
5. Use brackets with M8 thread connection to mount the unit.
6. Connect the black 4mm hose with the 3/4" adapter to the mains water supply, for this use a 3/4" washing machine tap with check valve
7. Make sure that the water pressure is between 1.5 bar and max. 3.5 bar.
8. The humidifier is supplied with a 16 millimetre drain hose with a length of 50 centimetres.



Note! The drain hose must be connected to the sewer depressurized and with sufficient drop/ slope! NO water may remain in the hose!

9. The water consumption is a maximum of 1l/min in case of a pipe fracture or faulty water supply valve, normal use max 2l/hour. The minimum diameter of the drain must be 25 millimetres.
10. Fit the humidity and temperature sensor (SHC80) as close as possible after the unit in the air duct to the dwelling, maximum distance 100 centimetres.



Note The sensor(s) must not be damaged or get wet!

11. Open the water supply tap and check for leaks in the water supply and the drain.
12. Insert the plug into the socket. Check the voltage, green power LED comes on and the service LED will go on for 5 sec and off for 5 sec. This means that the test cycles is started. The valve will open for 90 sec and the heater will go on for 30 sec.
13. Check the drain again for correct operation after 1 hour.
14. The humidifier is now ready for operation.
15. Open the packaging of the control panel and follow the instructions in the manual.

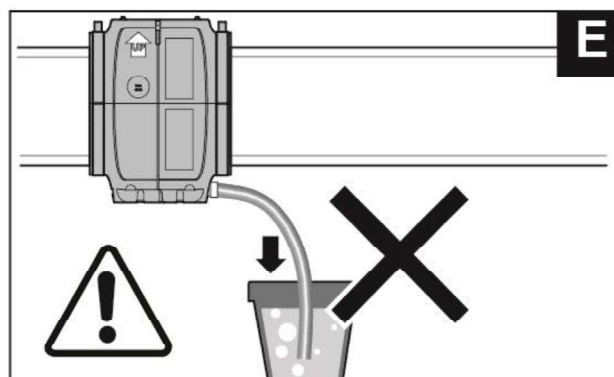
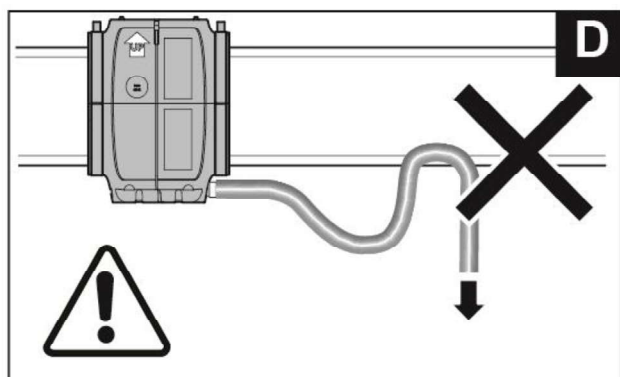
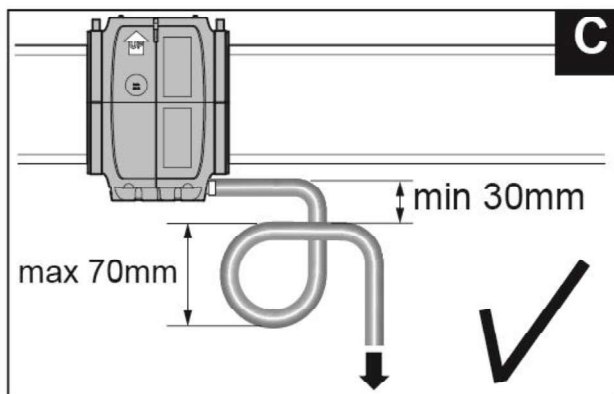
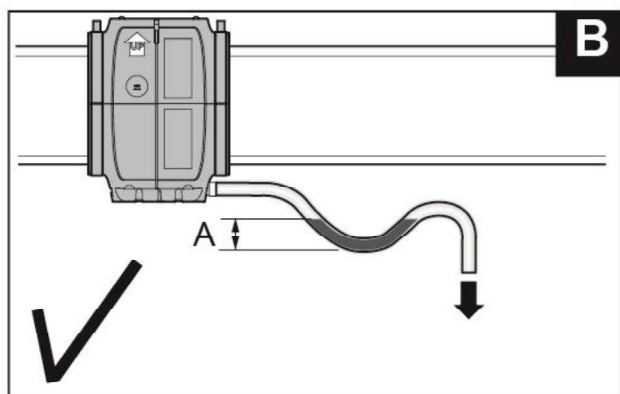
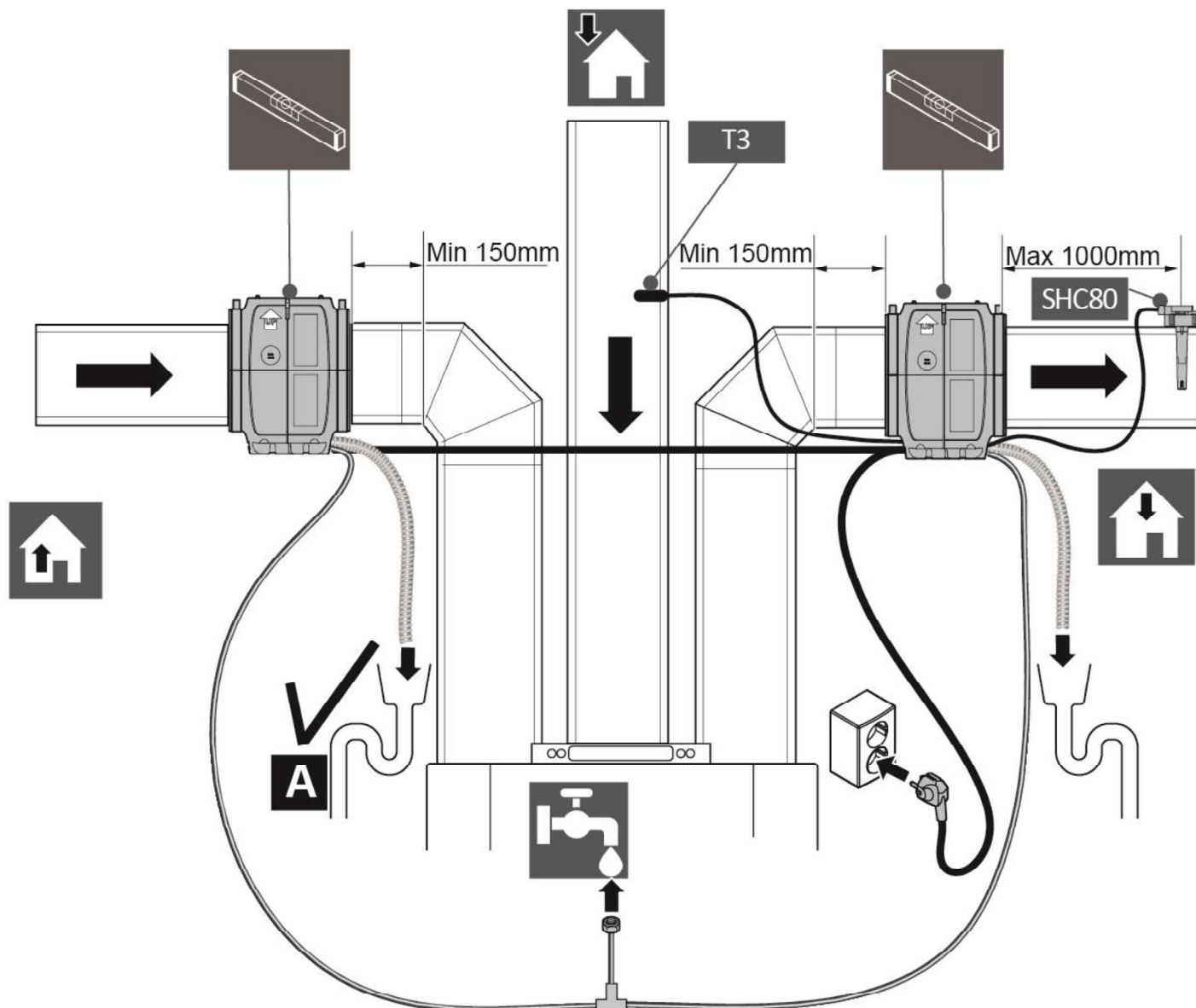

SECTOR 7

ALARMS AND FAULTS

When the control in the unit detects a fault, this is displayed at the bottom of the product by the alarm symbol (bell) by means of an LED. To reset the alarm the product must be briefly disconnected from the power supply by removing the plug from the socket and then replacing this in the socket after 10 seconds.

The Table below shows different causes of an alarm and the repair or control action.

Alarm LED	Display Tekst	Meaning	Action
Alarm LED on	<i>M OFF</i>	Contact main enable broken, unit switches off	Restore contact main enable, see wiring diagram
Alarm LED blinks 3 times	<i>SENSUP</i>	Contact with SHC80 sensor broken	Check SHC80 wiring and if necessary repair, check that the light on SCH80 sensor flashes regularly, if not replace faulty sensor.
Alarm LED blinks 5 times	<i>OUTDEF</i>	T3 sensor outside air faulty	Check wiring for break or wear, in case of doubt replace. Testing can be done by keeping the sensor at 8°C or colder in water or air; the Evap must then be activated because the water valve opens.
Alarm LED blinks 9 times	<i>WATER</i>	No rise of RH in duct	Check that the water tap is open <ul style="list-style-type: none"> If tap is open and there is a demand (outside air below 12°C) disconnect the black hose on top on the knee joint and activate the water valve by switching the voltage off and back on again, water should now come out of the hose; if valve does not respond, replace valve. If valve is working and matrix material does not get wet after switching, then the LegioSafe filter is blocked and must be replaced. Order product code 351025 from your dealer.
Alarm LED blinks 11 times	<i>NOAIR</i>	No airflow Cooler	Check if HRAV is working
Alarm LED blinks 13 times	<i>NOCOOL</i>	No water Cooler	Check that the water tap is open. <ul style="list-style-type: none"> If the faucet is open and there is a demand (for the combination comfort outside temperature must be below 12 ° C) disconnect the black supply hose from the knee on the unit, and reset the unit by plugging the plug in and plugging it in again. ; if water comes out and the water valve does not respond, the water valve is defective, replace the water valve. Does the water valve work and the matrix does not get wet after the valve has switched, then the legionella filter is clogged; replace the cassette.
Alarm LED blinks 15 times	<i>HEATER</i>	Heating faulty	Check air temperature after the humidifier, this must be >8°C, if not air heater is faulty. Call installer for replacement.
Alarm LED blinks 17 times	<i>AIRFLW</i>	No airflow	Check if HRV is working.
Alarm LED blinks 19 times	<i>T2Def</i>	T2 sensor outside air faulty	Check wiring for break or wear, in case of doubt replace. Testing can be done by keeping the sensor at 8°C or colder in water or air; the Evap must then be activated because the water valve opens.
Service LED continuously on	<i>Service</i>		The cassette must be replaced

Section 8 – Maintenance

The humidifier is equipped with a removable cassette in which a matrix HEMATB and LegioSafe filter LS23FIL are fitted. The matrix cannot be cleaned but needs replacement every season to have optimum performance.

The cassette must be replaced at least every 3 years to guarantee safe and healthy humidification. A service message is triggered that is visible by a LED coming on (next to the lock symbol) at the bottom of the humidifier.



For further information we refer to the maintenance manual
On our website www.homevap.com

Section 9 – Wiring diagram

Wiring Diagram All units after September 2023 AF9 (V3.07->)

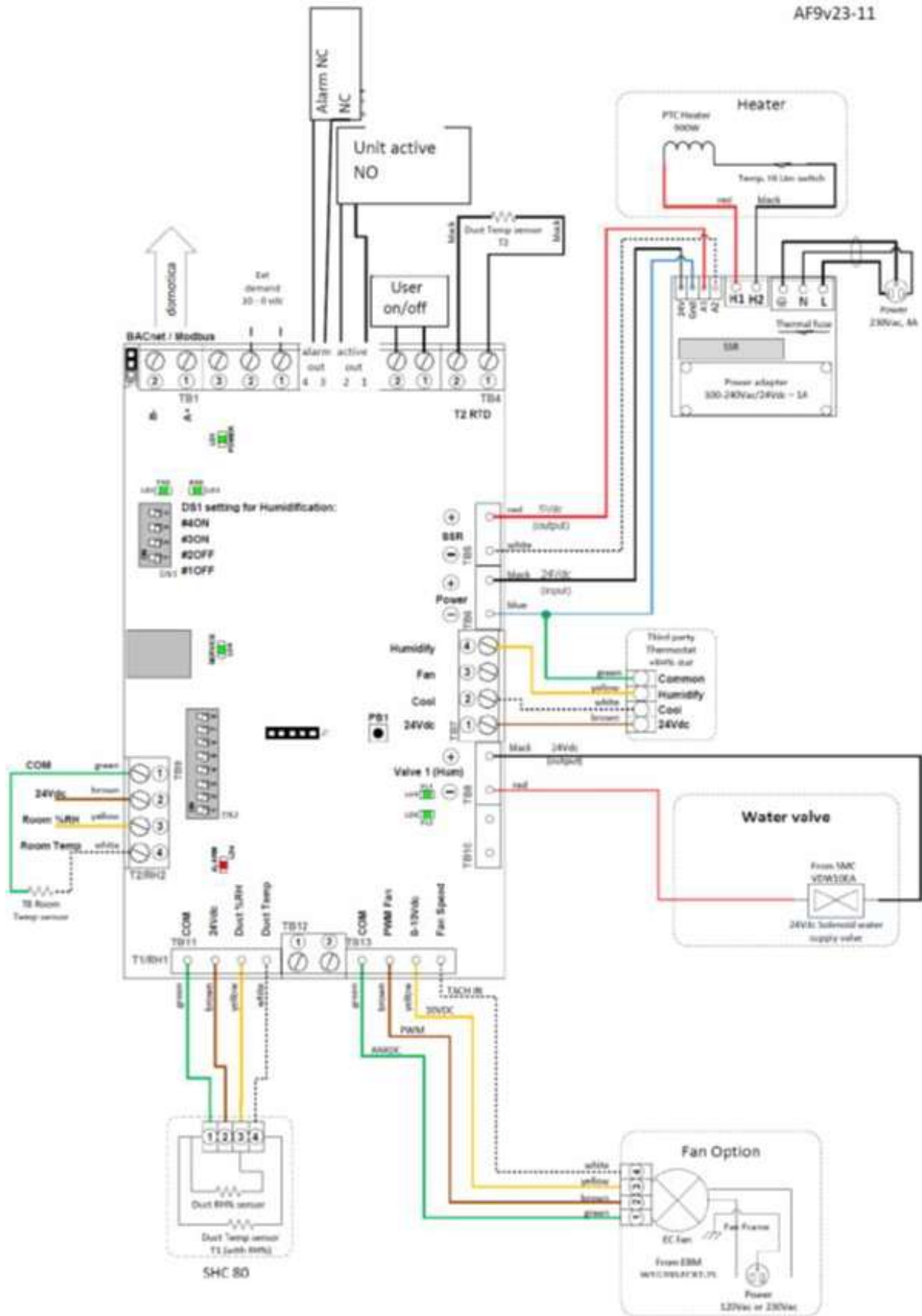

Wiring diagram Wired version HomEvap

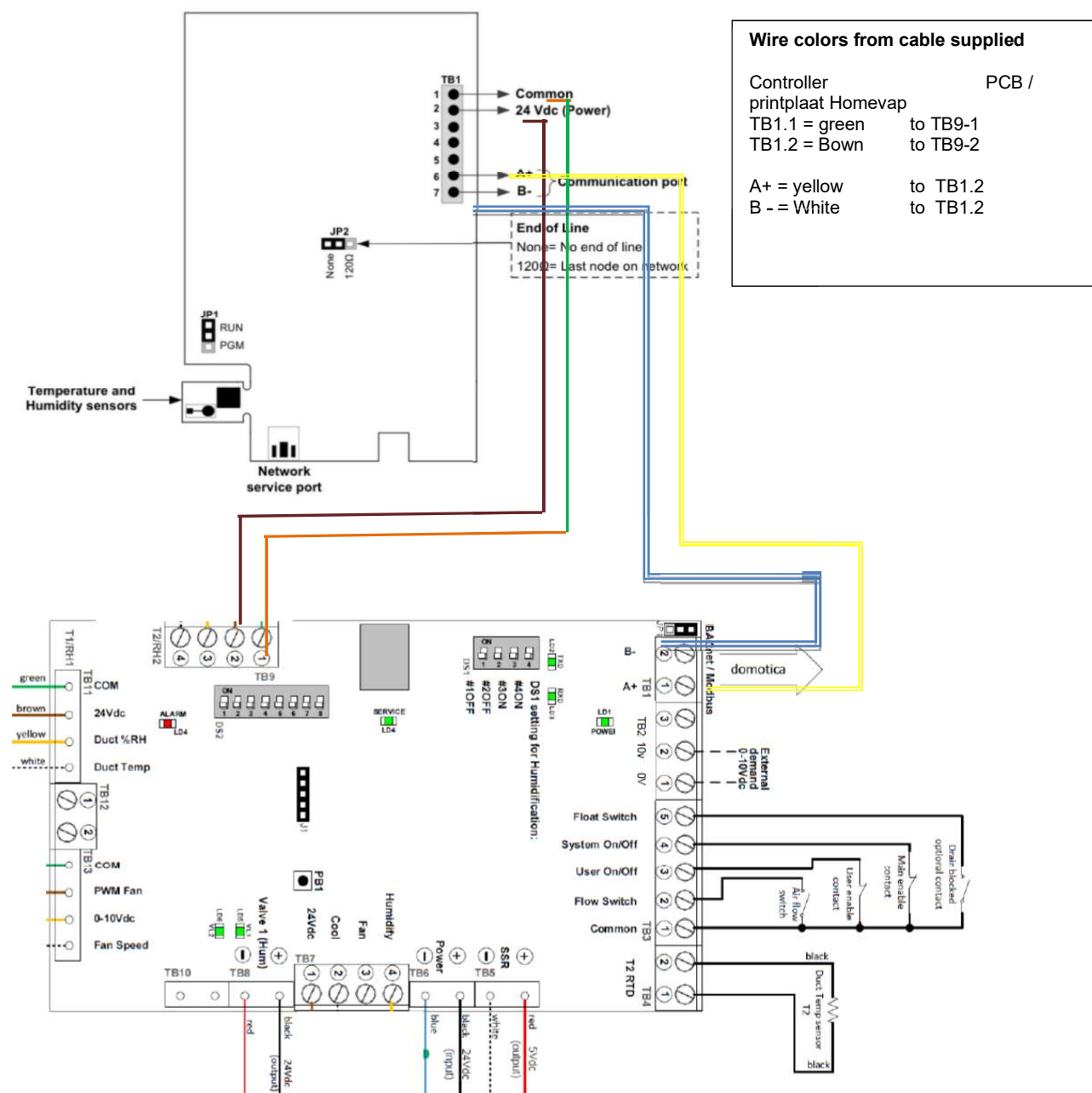

11. Service

When ordering components in addition to the product code the serial number (if present) and the name of the component must be stated.

11.1 Service products

Product description	Product code
Humidifier cassette	HEPCAH
Evaporation media	HEMATB
Legio Safe waterfilter complete	LS23FIL
LEgioSafe cartridge	LS23CAR
Humidifier air heater	HEPTC20S
Humidifier water valve	HEVDW12EA
Humidifier drain	HEAFVOER
Humidifier PCB 1	HEMAIN

We made the HomEvap easy to service, so pls check our website for the latest information on this.

www.homevap.com

Section 11 – Warranty provisions

- 11.1 HomEvap warrants that the supplied goods and/or their components shall for a set period after delivery be free of faults that are the direct consequence of material, production and/or construction faults. The duration of the warranty shall be:
- 2 years from the installation date on all components of this product, except for any filter present, which is not covered by the warranty;
 - 5 years from the installation date on any heat exchanger present (except for enthalpy exchangers; for this the warranty period of 2 years shall apply).
- 11.2 Based on various ^{TB2 10V 0V} standards and requirements for each country the warranty provided by HomEvap shall only be valid if the product is installed in the country of first purchase.
- 11.3 In derogation of the provision in paragraph 1 of this Article the warranty for goods that HomEvap has obtained from third parties or has had developed and/or manufactured by third parties shall be limited to the warranty that these third parties have given to HomEvap.
- 11.4 A claim under warranty shall only be considered by HomEvap if this is submitted to HomEvap in writing within 14 days after the fault is discovered or should reasonably have been discovered.
- 11.5 All warranty claims shall lapse if:
- the other party has himself made modifications or repairs to the goods supplied or had them made by third parties without the prior consent of HomEvap;
 - there has been improper use and/or use for purposes other than the original, normal use;
 - the fitting instructions or user manual have not been strictly followed;
 - upon fitting, components other than the original (and included) HomEvap components have been used;
 - the fault is the result of causes other than material, production and/or construction faults;
 - delivery of used (2nd hand) materials, components or goods is agreed;
 - no maintenance, or incorrect or insufficient maintenance has been carried out;
 - the fault is a result of normal wear and tear.
- 11.6 Minor deviations in size, colour, weight or number shall not form grounds for a claim under warranty.
- 11.7 The costs of repairs to the goods supplied, that the other party has carried out himself or had carried out by third parties without the prior consent of HomEvap, shall never be for account of HomEvap.
- 11.8 As a result of its warranty obligations, HomEvap shall only be obliged to repair or replace goods or components supplied by it for its account, at the discretion of HomEvap, if the product is installed in the country of first purchase. HomEvap reserves the right to charge to the other party additional costs such as for example travel, accommodation and wage costs and the costs of dispatch and (dis)assembly.
- 11.9 If HomEvap replaces goods or their components to comply with its warranty obligation, the replaced goods or components shall become the property of HomEvap at the time of replacement.
- 11.10 Returns shall only be accepted after prior written consent of HomEvap. Return shall be carried out for account and risk of the other party.

Section 12 – Liability

Use according to intended purpose

The product, described in this documentation, has been designed for the adiabatic humidification of frost-free rooms in high-rise and low-rise buildings. Any other use falls outside the intended use of the product. No liability can be accepted for damage arising due to incorrect use.

- 12.1 For faults in goods supplied only the warranty described in Section 11 (Warranty) shall apply.
- 12.2 HomEvap shall under no circumstances be liable to the other party and/or third parties for consequential damage, such as damage in the form of loss of profit, loss suffered including production loss, costs of shutdown or delay, penalties and other indirect damage.
- 12.3 The liability of HomEvap shall be limited to a maximum of the amount for which HomEvap has covered liability by insurance.
- 12.4 If HomEvap's insurer does not make a payment in any case or the damage is not covered by the insurance, the liability of HomEvap shall be limited to the invoice value of the relevant agreement.
- 12.5 The other party shall indemnify HomEvap for claims of third parties to reimbursement of damage for which HomEvap is not liable based on the previous paragraphs of this Article.
- 12.6 The other party shall inform HomEvap as soon as possible in writing of claims for compensation as described in this Article.

